



SPACEMANIC

BUILDING THE SPACE INFRASTRUCTURE OF THE FUTURE

Ota Michálek

Chief Strategy Officer

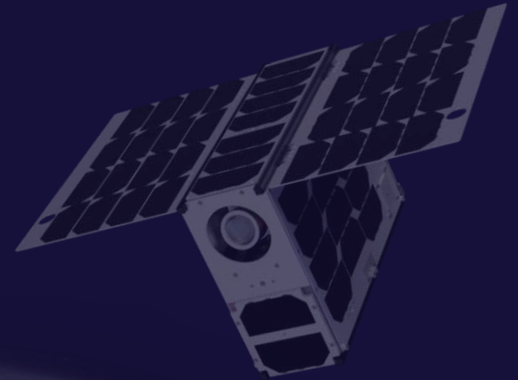
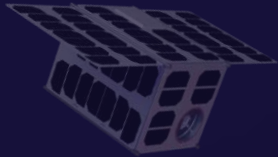



Source: [Czech Space Portal](#)

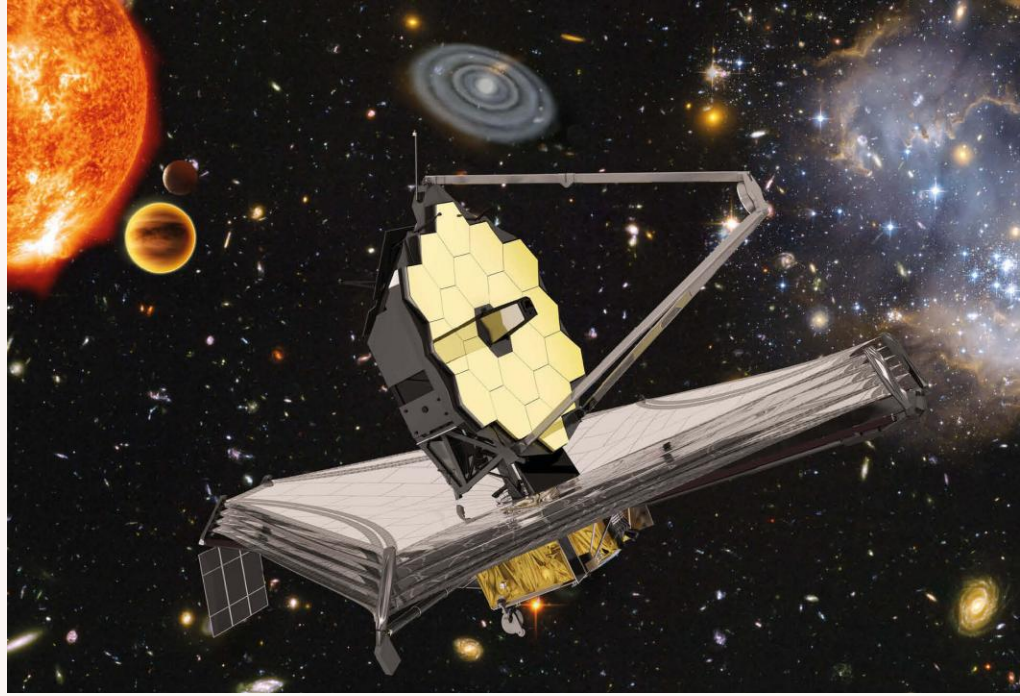

Source: [ESA Website](#)

ESTABLISHMENTS AND FACILITIES

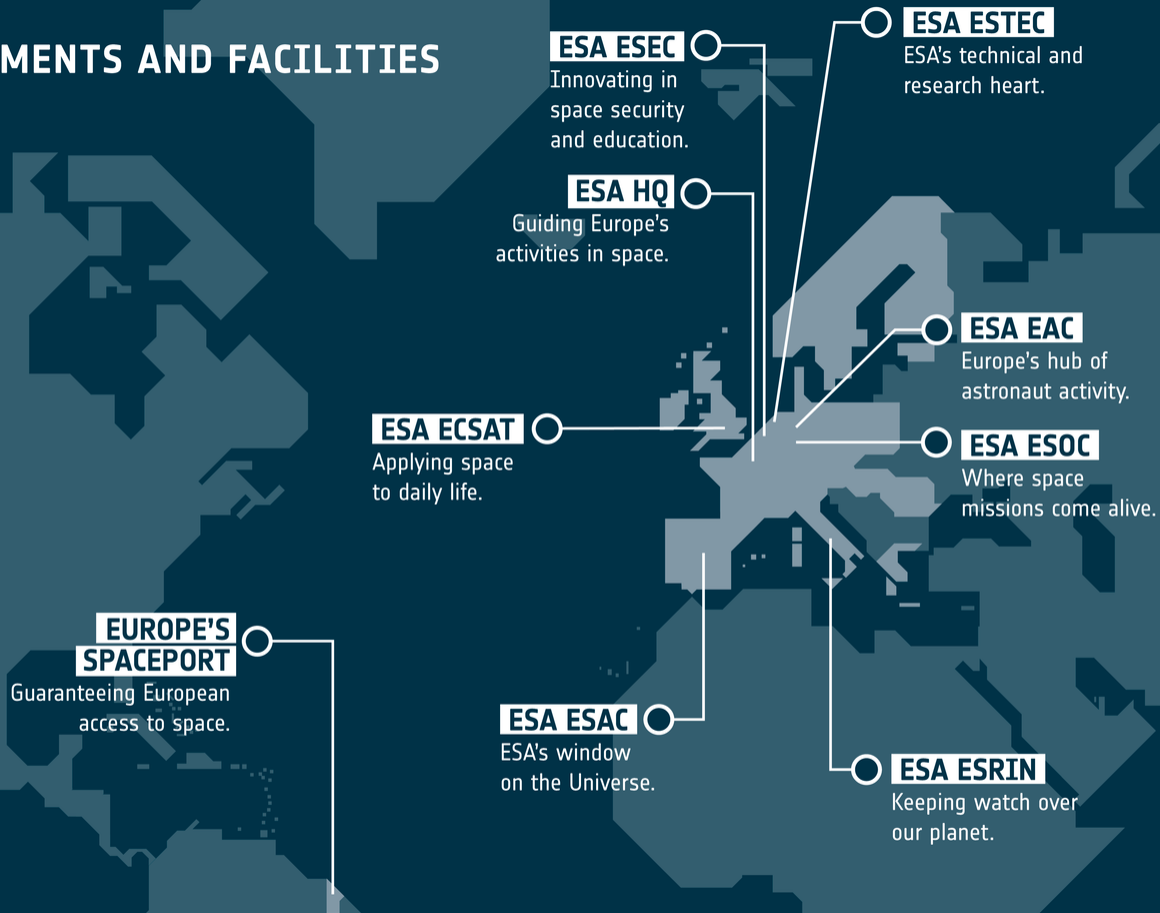





Source: [ESA Website](#)



Source: [ESA Website](#)



Source: [ESA Website](#)

Jak to všechno sledovat?

- Česká cesta do vesmíru: <https://ceskacestadovesmiru.cz/>
- Czech Space Portal: <https://www.czechspaceportal.cz/>
- Kosmonautix: <https://kosmonautix.cz/>
- Kosmické novinky: <https://www.youtube.com/@kosmickenovinky>



SPACEMANIC

BUILDING THE SPACE INFRASTRUCTURE OF THE FUTURE

SUBSYSTEMS
CUBESAT PLATFORMS
SERVICES

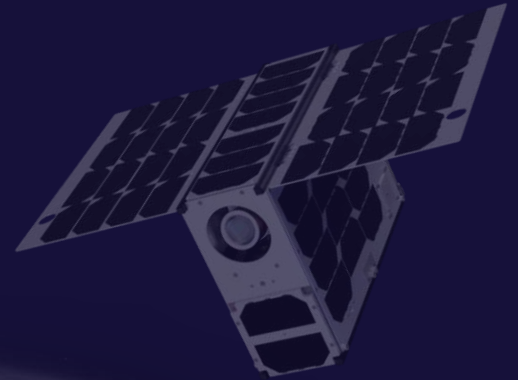
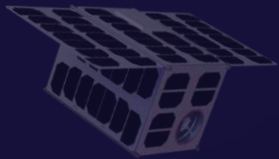

HISTORY

SPACEMANIC HAS BUILT A STRONG POSITION IN THE INDUSTRY VIA **COMMERCIAL MISSIONS**.



Spacemanic established following the skCube success

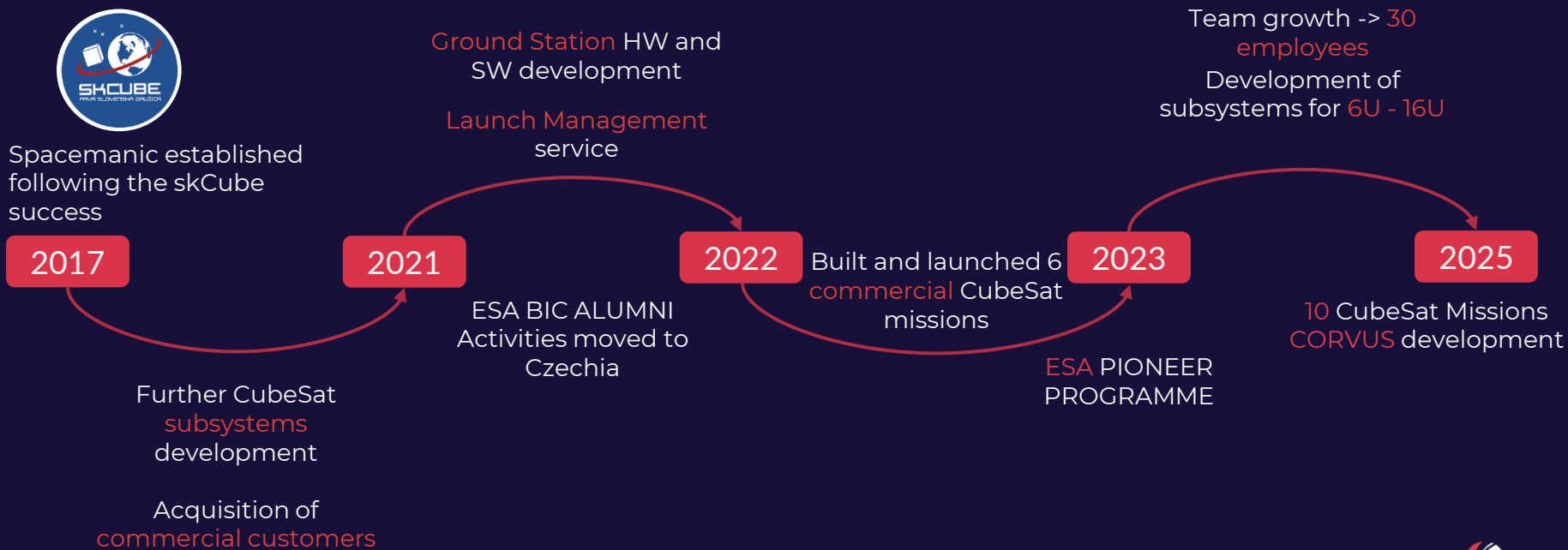

SUBSYSTEMS

- Communication
- Power Systems
- Command and Data Handling
- Navigation
- Attitude
- Structures
- FlatSat
- SchoolSat

MURGAS, Antenna Module, SDR

AMUN PSU, RA Solar Panels

EDDIE, DEEP THOUGHT

CELESTE + Antenna

ATTITUDE DUDE, LODESTONE

NEO

1U-16U Structures

Development kit

Educational CubeSat



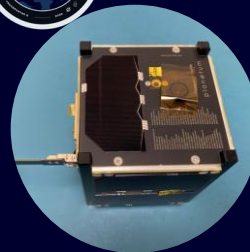
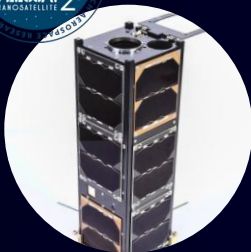
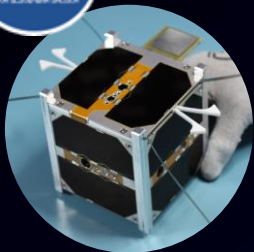

2017

10 SUCCESSFUL MISSIONS

2025



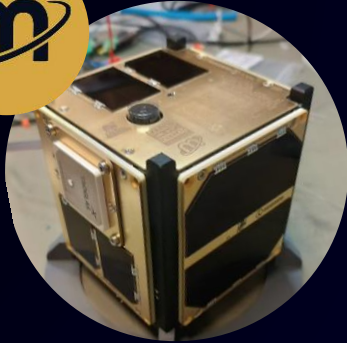

MARINA

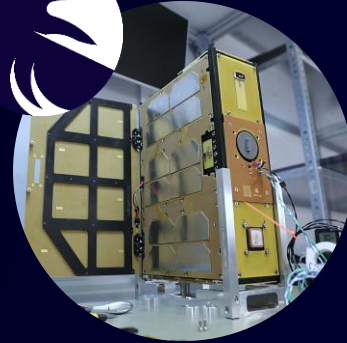

CORVUS - IOV

2026

UPCOMING MISSIONS

2027

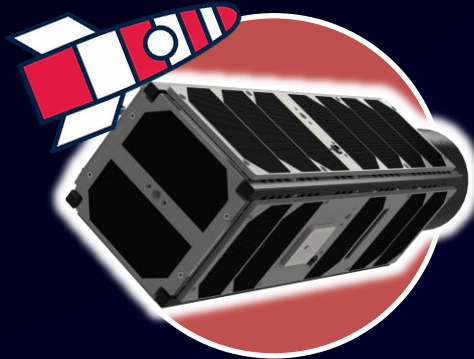

BRNOSAT

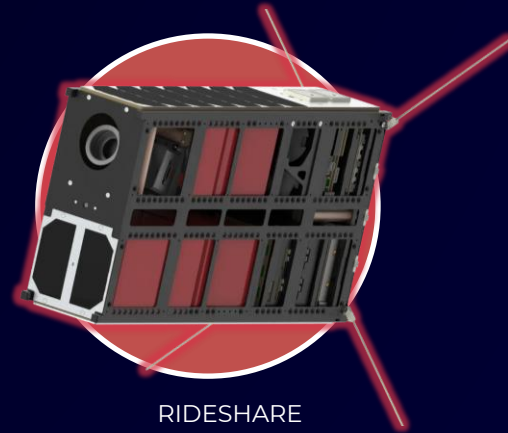

RIDESHARE





CORVUS

6U-16U Nanosatellite Platform

- **ESA PIONEER PROGRAM**
- **IOV in 2027**

APPLICATIONS:

- In-Orbit Validation Missions
- IoT and Secure Communication
- Telecommunication
- Space Debris Monitoring
- Earth Observation
- Space Weather Monitoring
- Defence Applications
- Constellations

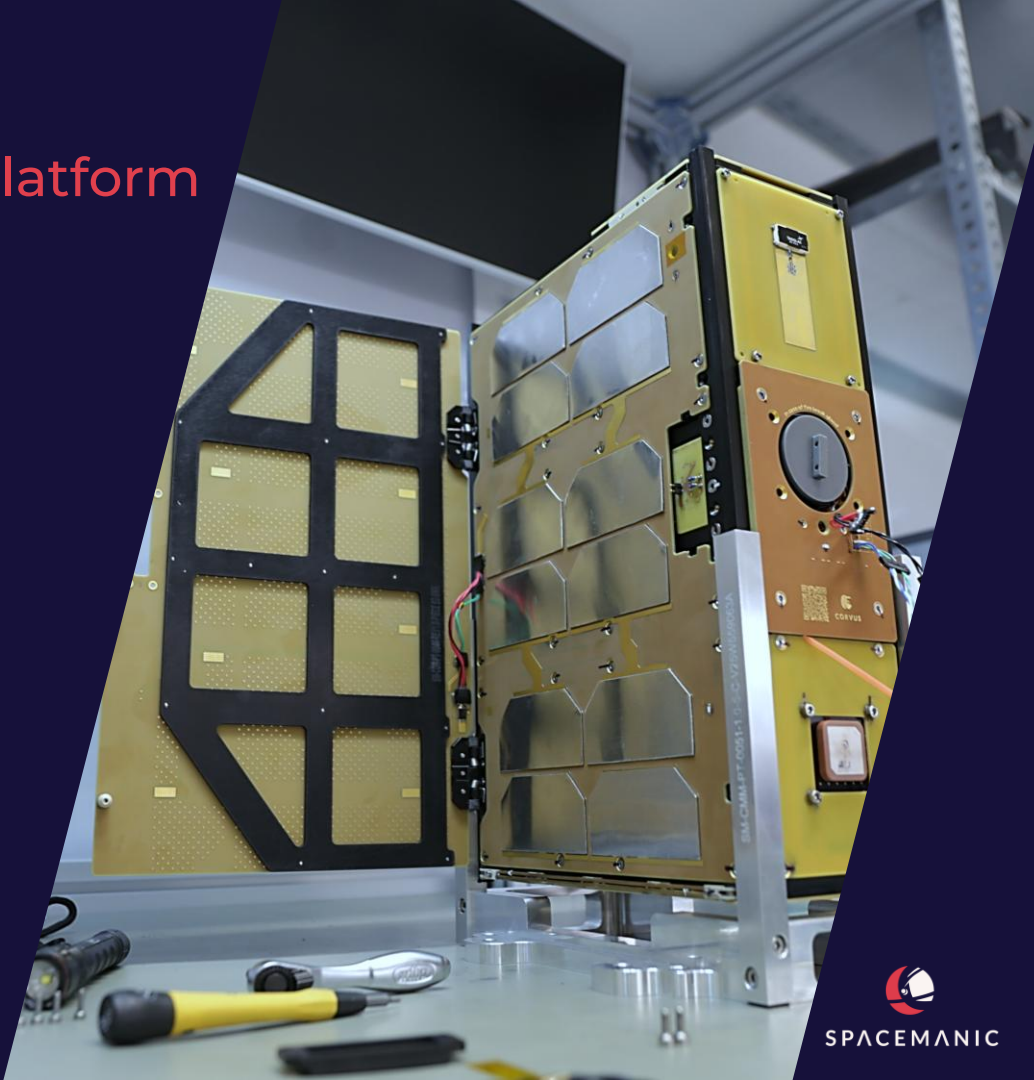

BRNOSat

3U Satellite Platform

Launch in 2027

Payloads from Brno institutions:

- Brno University of Technology
- Masaryk University
- Brno Observatory and Planetarium

Purpose:

IOV/IOD, scientific measurements, technology demo,
software validation

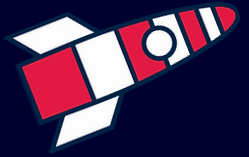
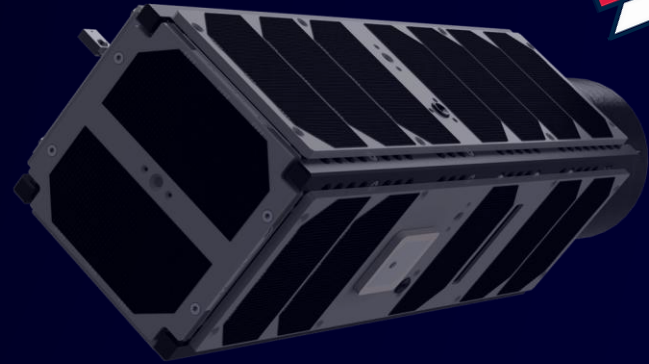

RIDESHARE

8U Satellite Platform

Launch in 2027 | 2029 | 2031

4U available for payloads

300 000 € per 1U slot (scalable!)

Payload submission until **31st March 2026**

Payload user guide:



<https://gitlab.com/spacemanic-public/payload-guide>



RIDESHARE:



SPACEMANIC

Rideshare flights

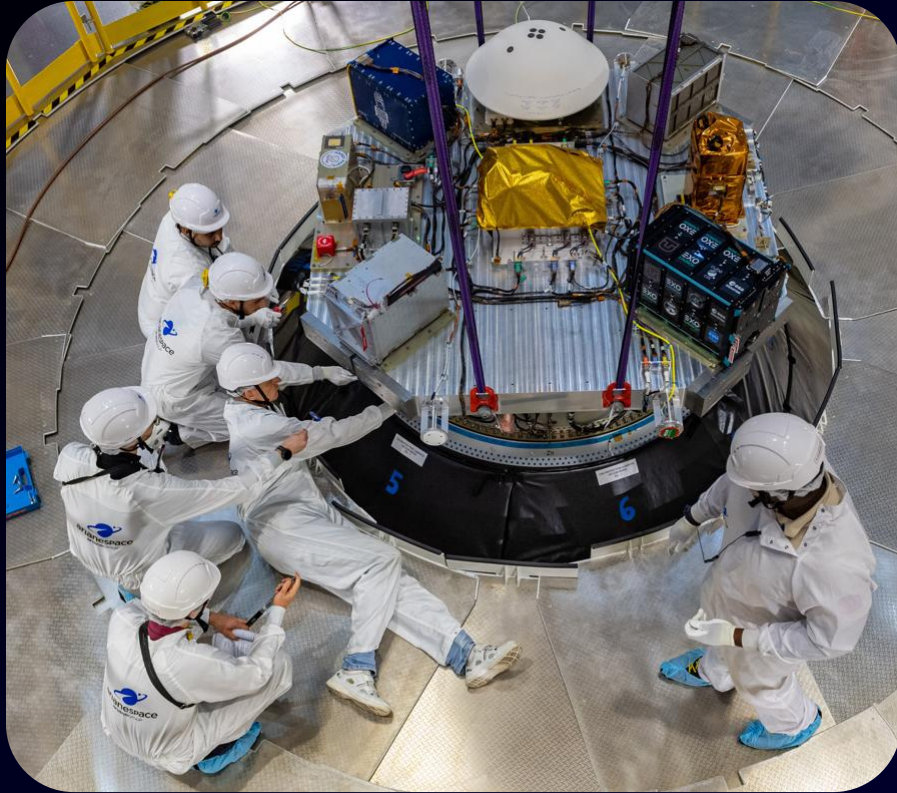

GRBBeta on Ariane 6



SpaceX: Transporter payloads

ESA & other projects

Collaboration between university and industry

Early-stage developments (TRL 1 to TRL 3)

- Check OSIP, local grants and funding opportunities

Advanced developments (TRL 3 to TRL 9)

- Check ESA Star, local grants and funding opportunities

The Open Space Innovation Platform (OSIP)



(Near) Future...

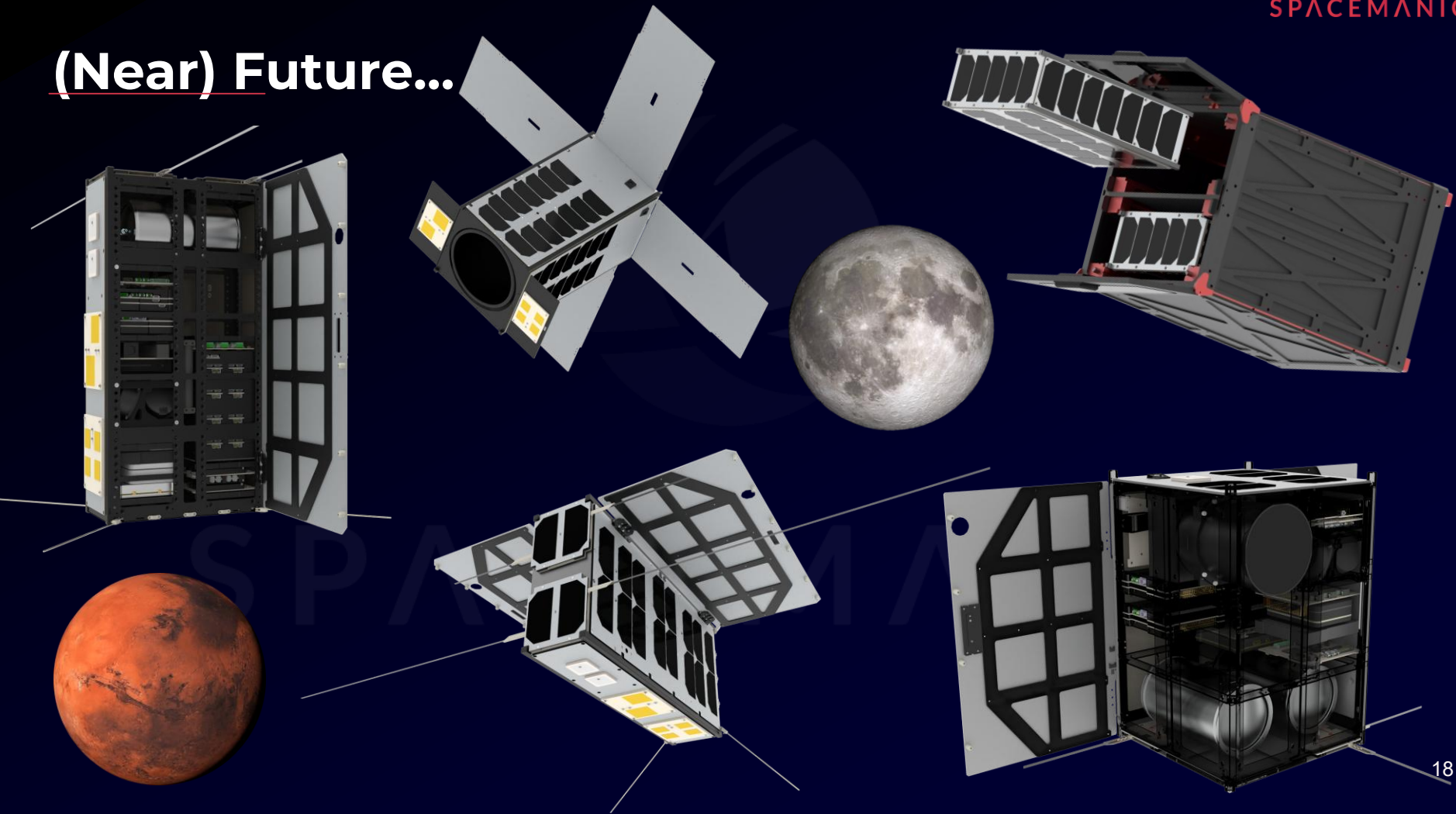

TL;DR

- The CORVUS platform and parallel mission practical experience
- CORVUS IOV under active development under the ESA Pioneer Programme
- Spacemanic heritage in CubeSat missions + best practices from ESA
- Balance between NewSpace approach and structured ESA methodologies
- Focusing on system engineering, risk management, and scalability (1-16U)
- Legal, Constellations, Clean Space & Kahoot

Ota Michálek

- CSO, Systems Engineer
- Supporting system engineer for CORVUS
- SysEng of BRNOsat, EARS
- MEng Aerospace Engineering (Systems)
@ University of the West of England, Bristol

Agenda, a.k.a Bare Minimum to Build a CubeSat

- Requirements and Verification & Validation (V&V)
- Design Definition: Function Tree, Product Tree and other diagrams
- Shopping List – buy or develop
- Preparing for the Worst: Failure Detection Isolation and Recovery (FDIR)
- Interface Control
- Necessary Legal Steps
- Mass, Power, Link, Data Storage and AOCS Budgets
- Concept of Operations (CONOPS)
- Constellations
- Clean Space
- Q&A, Discussion

CubeSat?



CubeSat

- Defined in 1999 (Cal Poly, Stanford) as ~10cm cube 1U
- Large popularity jump ~2012, then ~2017
- Started as mostly educational projects, but
- Found usage in commercial activities as standard matures
- Mostly inspired by PC104 industrial computers
- PCB stacking
- Today's trend are smaller modules integrated not only to PC104 motherboards

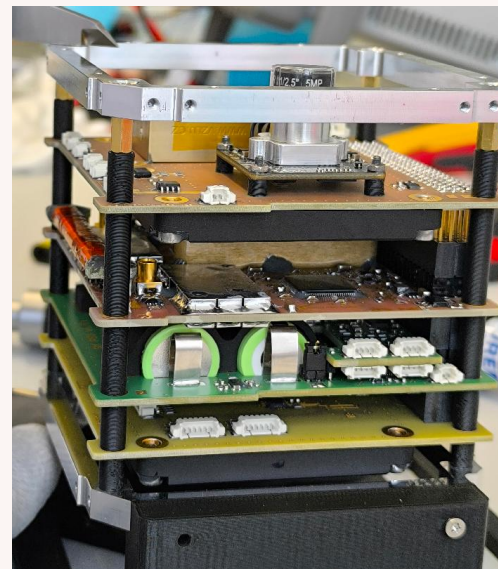
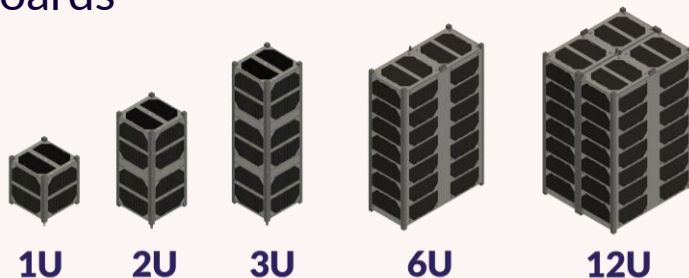

Integration

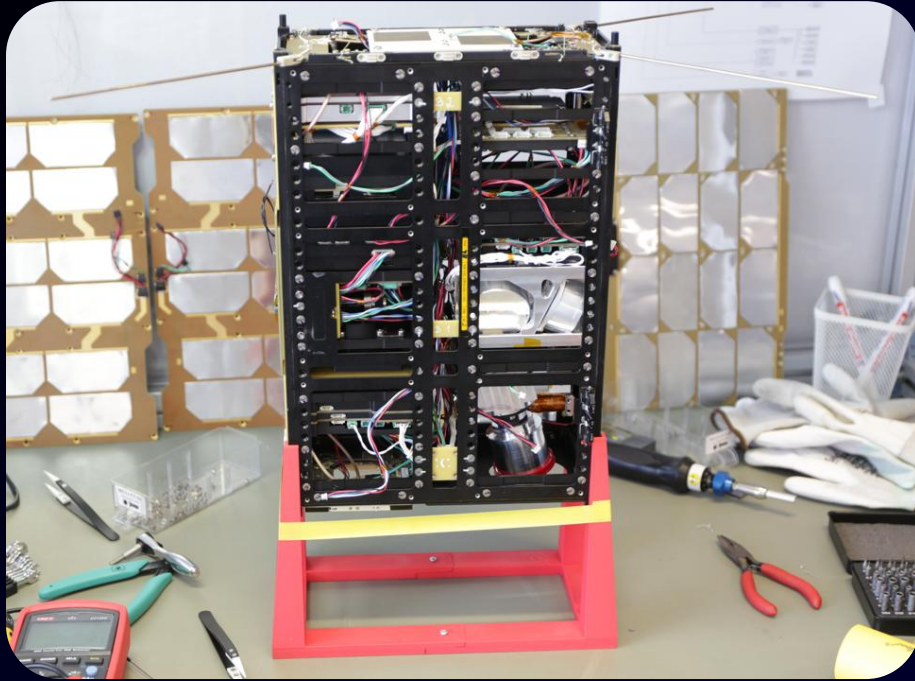

CORVUS: EQM integration



MARINA: integration day



Environmental Testing

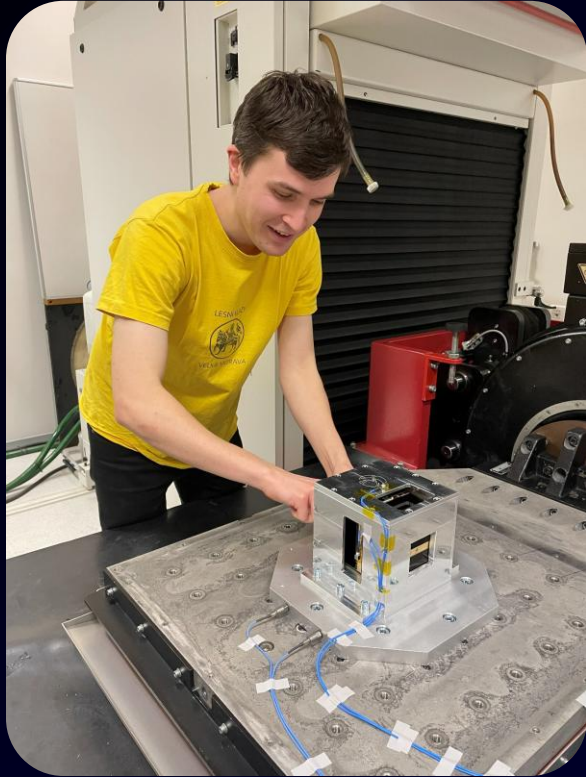

MARINA: vibration testing

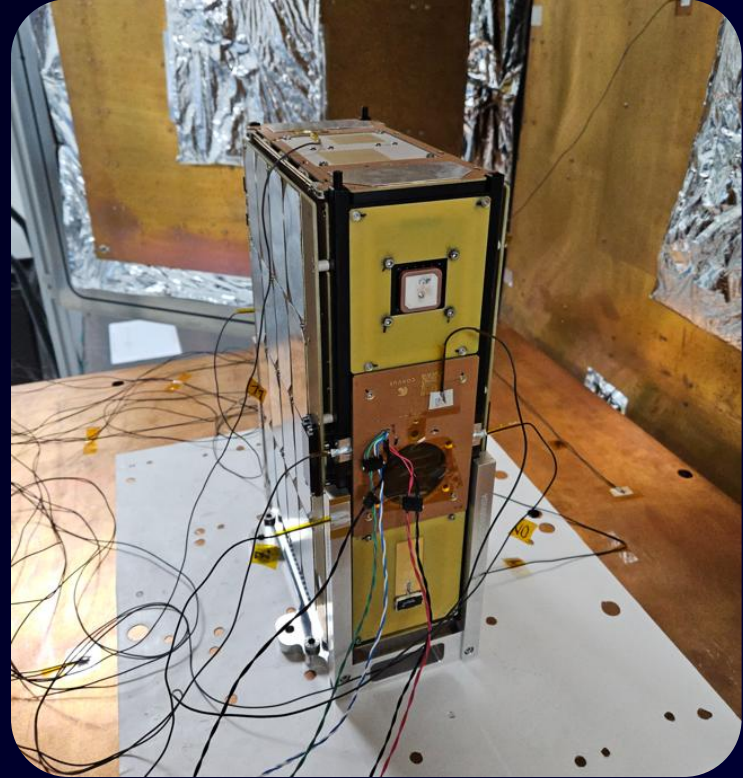

CORVUS: TVAC testing



Deployer Integration



GRBBeta: deployer integration

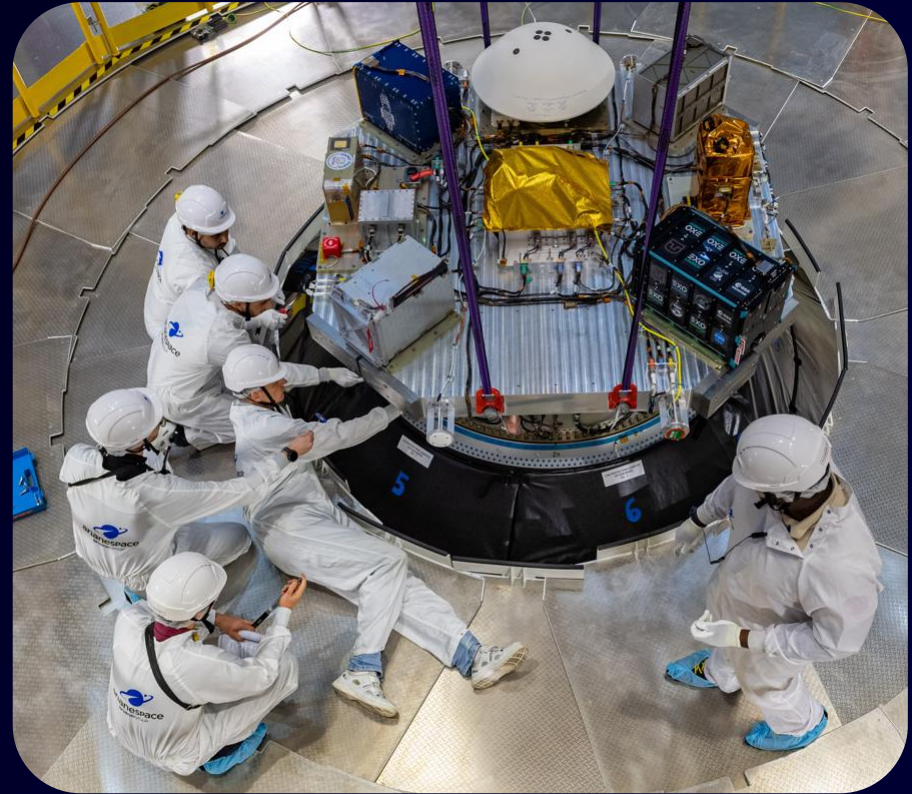

GRBBeta: Deployer to Ariane 6



SATELLITE OPERATIONS

Telemetry / BDSat-2

2023-02-15 00:00:00 to 2024-02-15 23:59:59 UTC



Selected frames count

44669

Last Frame Received

2024-02-15 21:26:00

Last Frame Received

a year ago

Last Frame Received By

OK2PNQ_omni_Letnice2-JN89le

Ground Stations Leaderboard By Observed Frames

station	count
ESL_lab_Bmo	24156
Piszkesteto UHF	9236
EU1XX	6254
F5WK	5508
EU1AEM	4668
OK2PNQ_omni_Letnice	3623
OK2PNQ_omni_Letnice2	2812
SP7THR-UHF	2410
SA2KNG Omni UHF/VHF	2085
PE0SAT-11	1732
UXSUL	1730

ASCI Telemetry (4 panels)

Power

PSU Battery

8.21 V

Ground WDT

95

PSU Cur. In

0 mA

PSU Cur. Out

131 mA

PSU Uptime (s)

20482887

PSU Uptime Tot. (s)

35238187

PSU Uptime

33.9 week

PSU Uptime Tot.

1.12 year

System state

Full

PSU Resets in orbit

3

Battery Current (mA)

min max current

0 419 0

121 562 129

PSU Temperatures (°C)

min max current

11.91 23.13 19.75

12.45 24.66 19.86

PSU Channels

On	On	On	On	On	On	On
CH0	CH1	CH2	CH3	CH4	CH5	CH6

BDS Payload (11 panels)

OBC

OBC Resets in orbit

41

OBC Free Storage

1.494 MiB

OBC Uptime (s)

904768

OBC Uptime Tot. (s)

35253065

OBC Uptime

1.506 week

OBC Uptime Tot.

1.12 year

OBC Temperatures - temp. unavailable

min max current

10.52 °C 22.36 °C 19.40 °C

11.00 °C 22.88 °C 19.38 °C

Solar Temperatures

min max current

-19.9 °C 24.9 °C -12.7 °C

-20.4 °C 26.8 °C -15.0 °C

-18.1 °C 34.4 °C -13.4 °C

-20.5 °C 32.3 °C -14.6 °C

-38 °C 1 °C -29.7 °C

SPACEMANIC

A satellite is shown in space, oriented diagonally. It has a central body and several solar panels extending outwards. The background is a dark blue gradient.

What do I need?
Where to start?



System engineering?

- ECSS-E-ST-10C Rev. 1

- 4.1 The system engineering discipline

System engineering is an interdisciplinary approach governing the total technical effort to transform requirements into a system solution.

A system is an integrated set of elements to accomplish a defined objective. These elements include hardware, software, firmware, human resources, information, techniques, facilities services, and other support elements.

- System?

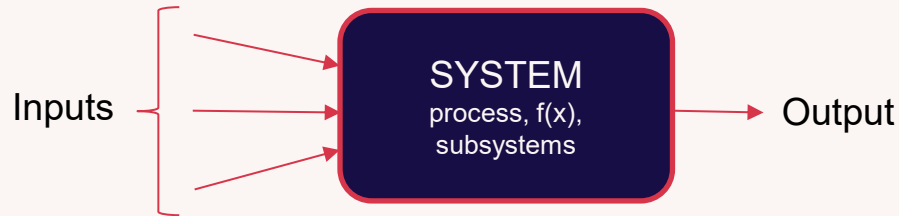

Let's consult ECSS (The European Cooperation for Space Standardization)



Let's consult ECSS

- 141 Active standards + 30 Handbooks
- SE: 9 Standards + 10 Handbooks (sometimes adoption of ISO)
 - ~806 pages of standards (+ Handbooks + non-SE + Datasheets + ICDs...)
- This is overwhelming
- The satellite is built out of its components not PDFs and paper
- "Common sense and engineering intuition" usually works
 - (often, with experience, we realize ECSS is actually right)

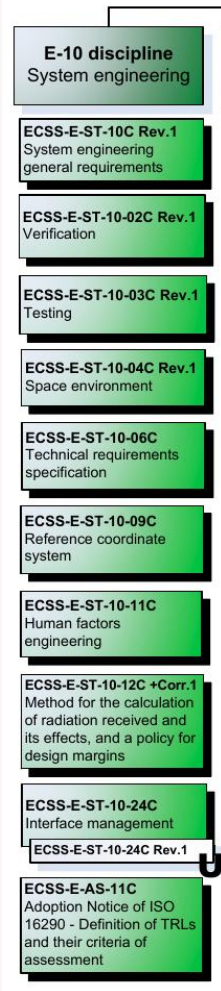

Traditional vs. New Space project milestones

- What is the traditional way? Phases? Reviews?



ECSS-M-ST-10C Rev. 1
6 March 2009

4.4 Project phasing

4.4.1 Introduction

The life cycle of space projects is typically divided into 7 phases, as follows:

- Phase 0 - Mission analysis/needs identification
- Phase A - Feasibility
- Phase B - Preliminary Definition
- Phase C - Detailed Definition
- Phase D - Qualification and Production
- Phase E - Utilization
- Phase F - Disposal

A typical project life cycle is illustrated in Figure 4-3.

Project phases are closely linked to activities on system and product level. Depending on the specific circumstances of a project and the acceptance of involved risk, activities can overlap project phases.

At the conclusion of the major activities and the related project reviews configuration baselines are established (see ECSS-M-ST-40).

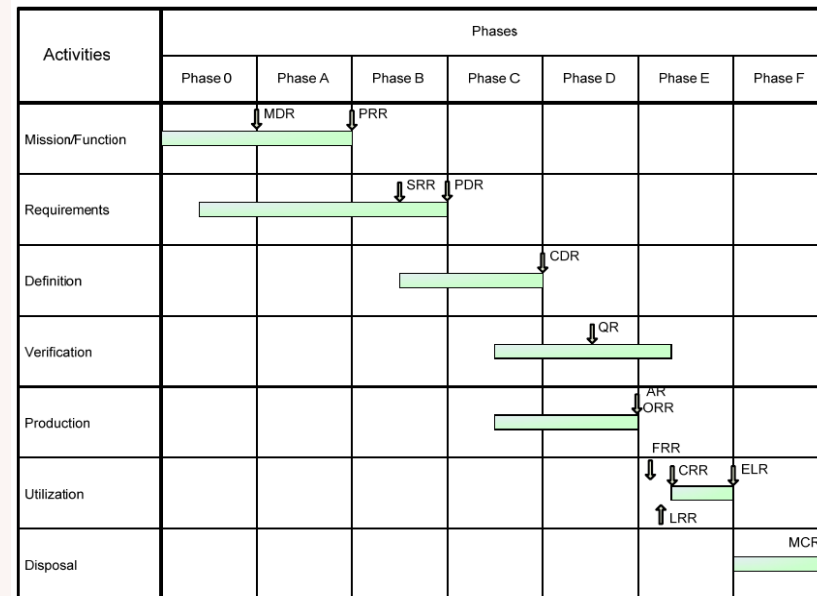
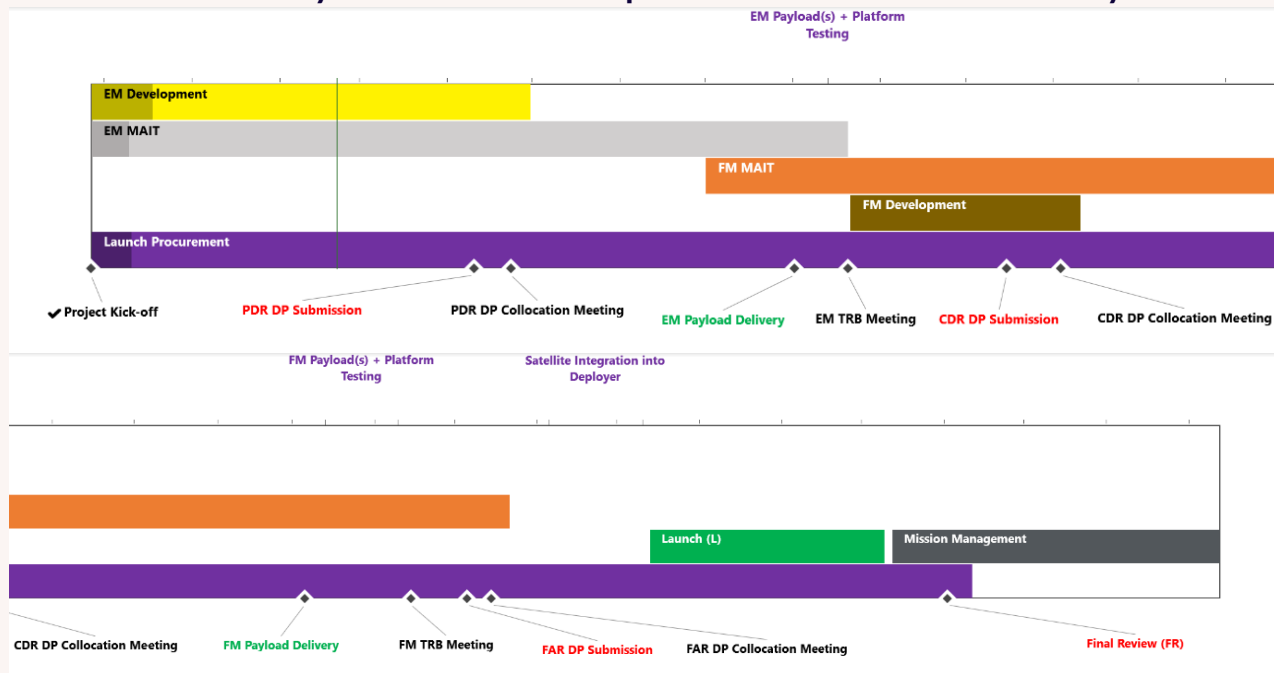

Figure 4-3: Typical project life cycle

Traditional vs. New Space project milestones

- What do we consider as practically important?
- Simplification is directly related to required lifetime/reliability



Requirements and Verification & Validation (V&V)

- Mission objectives (Technology? Scientific? Educational?)



- System requirements



- Subsystem requirements

- Verification and Validation

- Common to follow V management model

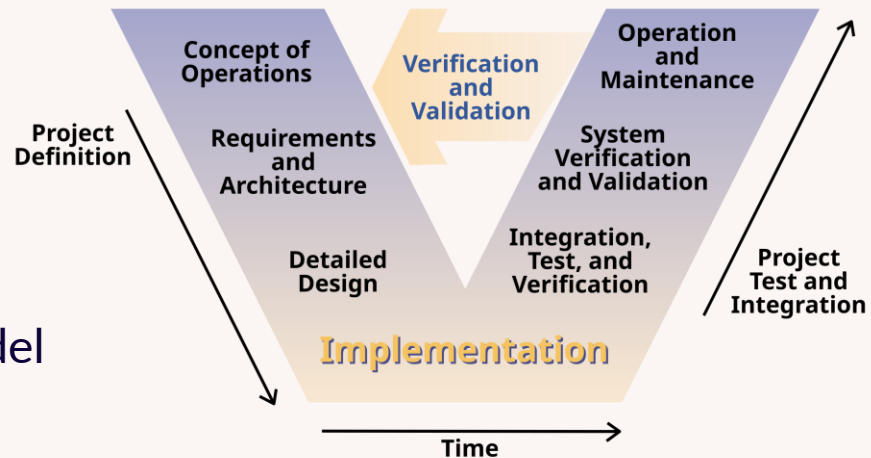

Requirements and Verification & Validation (V&V)

- Example from Corvus IOV mission
- Mission objective:
 - "Validate 6U CubeSat Platform and its subsystems"
- System requirement:
 - "The satellite platform shall be able to deliver 20MiB of payload data daily."
- Subsystem requirements:
 - "The COM UHF system shall implement FSK 9600 bps and FSK 19200 bps modes."
 - "The COM S-band system shall implement GMSK at 250 kbps communication for transmissions."

Design Definition: Function Tree, Product Tree and other...

Function tree example

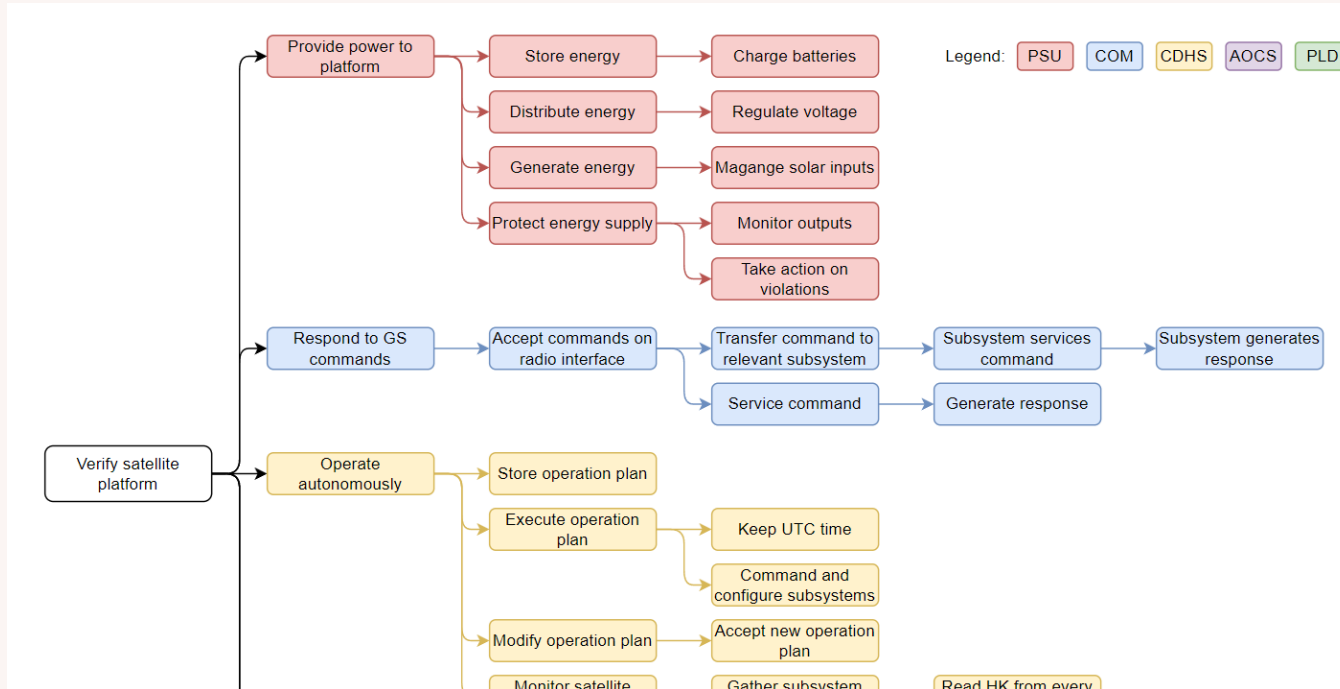

Design Definition: Function Tree, Product Tree and other...

Product tree example

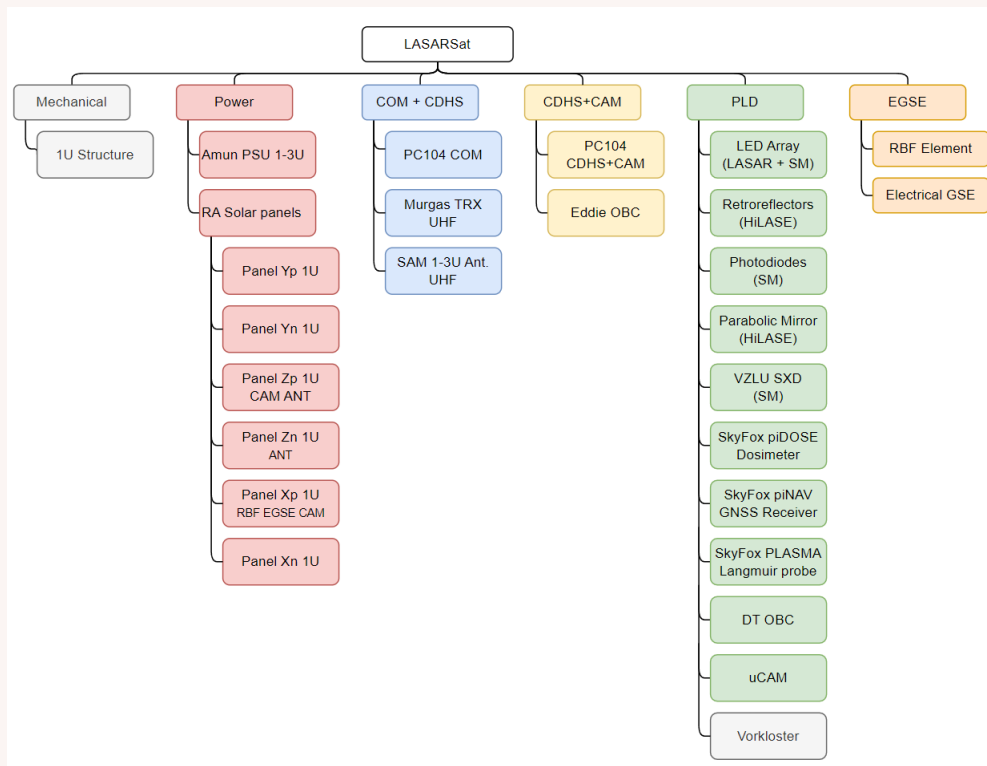

Shopping List – buy or develop

- Mechanical – structure, fasteners, deployment mechanisms
- Power – PSU, solar panels
- Communication – UHF, VHF, S-band, X-band
- CDHS – platform OBCs
- AOCS – RWs, MTQs, Sun sensors, gyroscope, magnetometers, STR
- Platform interfacing – harnessing, connectors
- GSE – Electrical GSE, Mechanical GSE
- Payloads



How is it going to work?
How do we actually make it?

Design Definition: Other Diagrams – Architectures

Internal bus architecture

Spacemanic (decentralized approach)

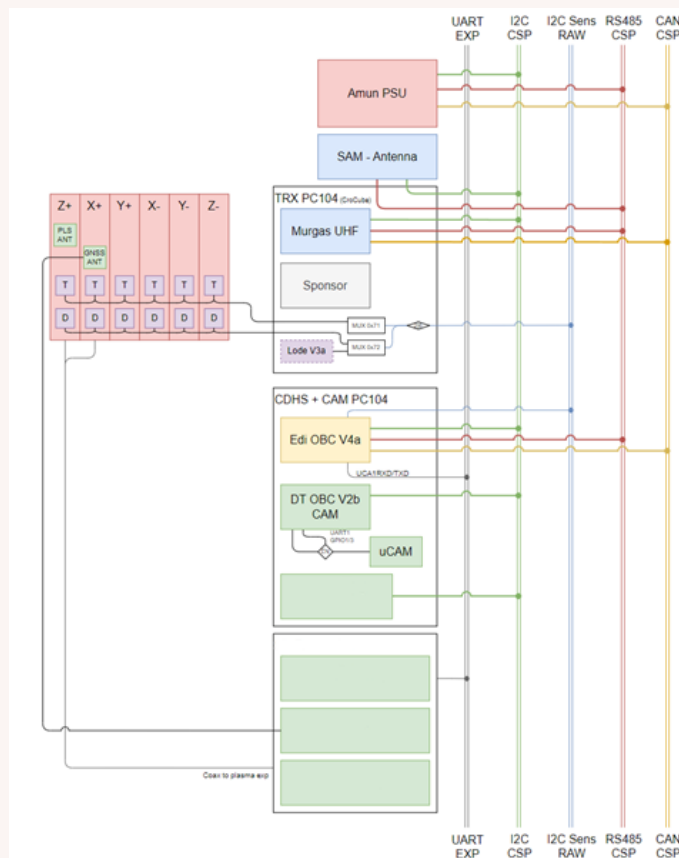

Design Definition: Other Diagrams – Architectures

Power distribution architecture

- Inputs
- Outputs
- Regulators
- What is powered by what

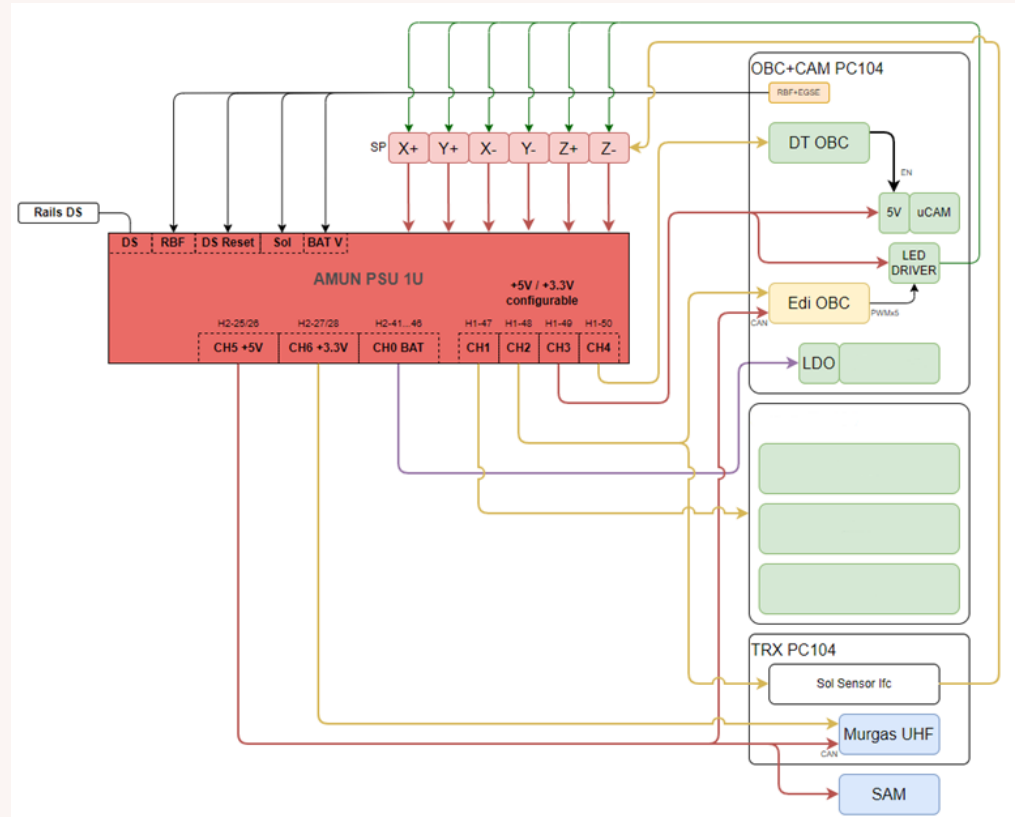

Design Definition: Other Diagrams – Architectures

Internal architecture – ORCASat (more centralized approach)

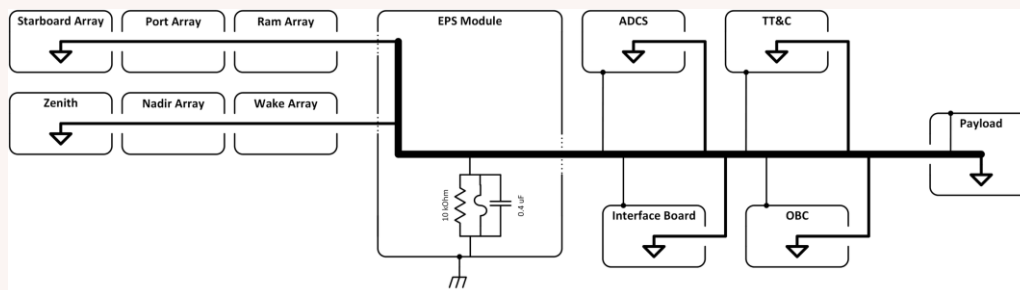
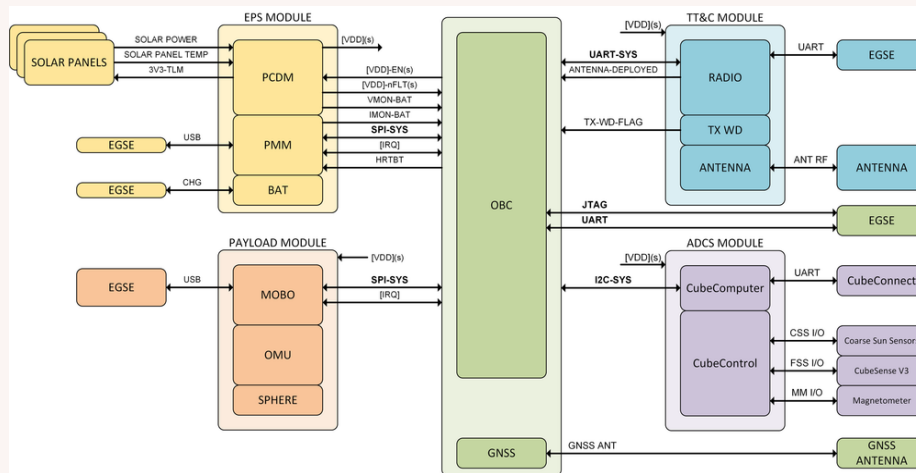

Failure Detection, Isolation and Recovery (FDIR)

- Redundancy is one of the strongest tools
 - But in nanosatellites we often don't have the space
- Analysis “on-paper” is the first step
 - Top-down (FTA)
 - Bottom-up (FMEA)
 - What-if



Failure Detection Isolation and Recovery (FDIR)

Identifier	Potential Fault	L	S	Detection Method	Isolation Strategy	Recovery Action(s)	Autonomy	Notes
MECH-F-01	Satellite failed to deploy due to getting stuck in the deployer	A	5	Reported by launch provider.	N/A	N/A	N/A	N/A
MECH-F-02	Failure of structure integrity or support structure integrity due to unexpected vibrations	A	5	Reported by the launch provider or determined from satellite data if the satellite communication system and CDHS is functional.	N/A	N/A	N/A	The satellite is qualified for launch per launch provider requirements to the <u>protoflight</u> level.
MECH-F-03	Solar panels failed to deploy completely due to hinge or spring failure	C	4	Solar panel HDRM feedback switch reports a closed state.	Check the performance of the solar panel underneath presumed to be completely covered by a non-deployed panel.	Manual command to deploy panel with extended HDRM burn time.	Operator	Fault severity depends on the state of deployment and voltage provided by semi-deployed panels. Covered by: SAT-T-5 (D) PSU-T-3 (I)
COM-F-02	Murgas TRX output power is low	A	3	Communication over UHF is performing badly, ground station shows low signal strength received	Check Murgas TRX housekeeping for information on the power amplifier state and configuration for configuration of power output.	<ol style="list-style-type: none"> Set desired power output via telecommand. Restart Murgas TRX. Restart Murgas TRX power via PSU. Adjust satellite operation for new link budget constraints. 	Operator	Covered by: COM-T-1 (I, R) COM-T-2 (D) COM-T-3 (I, R)
COM-F-03	Murgas TRX reception performance is weak	A	3	Communication over UHF is performing badly.	Check power consumed by Murgas TRX module to determine if LNA is functional.	<ol style="list-style-type: none"> Restart Murgas TRX. Restart Murgas TRX power via PSU. Adjust satellite operation for new link budget constraints. 	Operator	Covered by: PSU-T-3 (I) COM-T-1 (R)

Interface Control

- KISS and Verify
- **Simple solutions tend to be the best in practice**
- Multiple people (even non-technical staff) need to have a level of understanding
- **Optimal solution does not exist**
- More important to know limits and parameters of your solution than finding the optimal one ad infinitum
- Get inspired by non-space industries

- Coordination and control of interfaces has the largest contribution towards a working system

Interface Control - Mechanical

- **Satellite to launch vehicle**
 - CubeSat is a mature standard for nanosatellite missions
 - Smallsats use separation rings, CubeSats deployers
- **Payload/Subsystem within satellite**
 - How is a subsystem mounted inside the satellite?
 - CubeSats lean towards PC104
 - Modularity is key to be quick to react to changes
 - Always tailored
- **Thermal considerations**
- **Material considerations**

- **Nanosatellites are usually stiff/dense enough not to get worried**
 - Critical elements are deployable systems (solar panels, antennas, payload)



Interface Control – Electrical Hardware

- Comes from the system design/diagrams
 - What buses are we using? High speed Ethernet? Prone to noise?
 - Motivates choice of proper cables and connectors
 - Circles back to mechanical engineering for materials suitability
- Consider power and scale appropriately
 - Use at least two wires for power in case one gets loose
 - Bulky hardware is also difficult to work with in nanosatellite
- More applicable to actually read ECSS on this topic

Practical note: Harness diagrams

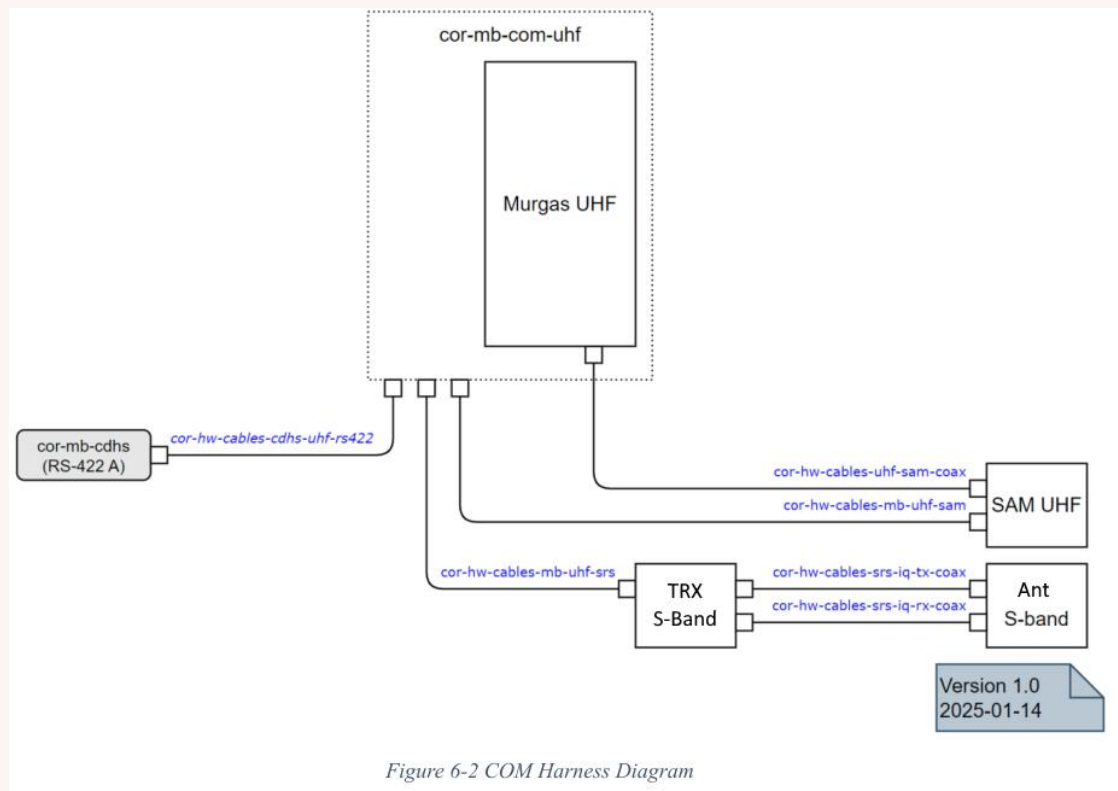
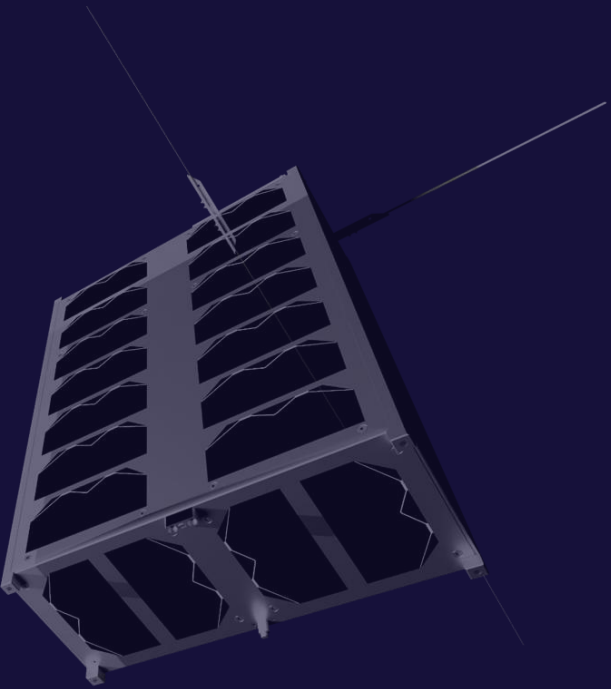

Figure 6-2 COM Harness Diagram

Interface Control - Software

- (You can work on software until the last minute...)
- Synchronize/establish protocols early
 - Individual "services" will evolve during development
 - Just don't change the whole concept every two weeks
- Today's IoT, Automotive, Industrial (also space) applications poured significant resources into reliable protocols/systems/standards etc. Exploit it directly or at least get inspired with your approach.
- Version your software and use source control!
 - Readability is key, someone will at some point need to interact with your code/product. Don't ruin their day...
- "Premature optimization is root of all evil"



Design

Budgets and Margin policy

- Assessment of my technology and suitability to fulfill system's needs
- Margin is usually some percentage applied on top of demand estimate
- Margin is per element VS a system margin
- Keeping large and unrealistic margins may result in over engineered system or in trying to develop unachievable system parameters
- Adjusting one budget table influences others somewhere
 - More batteries = more mass
 - More radio power = more power demand
 - Better computer = more power demand

Engineering Budgets

- **Mass Budget**
 - Large spacecraft pay launch by kilogram
 - CubeSats pay by unit – mainly limit check
- **Power Budget**
 - Size doesn't affect complexity
 - Compounding efficiencies
 - Complexity defined by number of modes and CONOPS
 - Many hardware limitations
- **Link Budget**
 - Need to budget both Up and Down
 - Radio communication is complicated field
 - Frequency (UHF, VHF, S-band, X-band, etc.) and encoding determine speed
 - Length of communication window

Engineering Budgets

- Data Storage Budget
 - Platform data – Telemetry, health indicators, FDIR logs
 - Payload data – depends heavily on mission
 - Very tight connection with Link Budget and CONOPS
- AOCS Budget
 - Budgeting of errors
 - Different sources – sensors, actuators, models
 - Very complex discipline

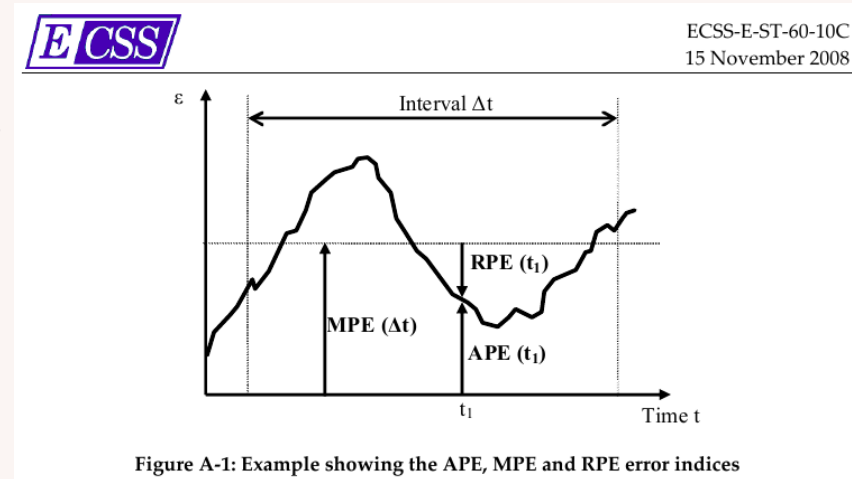

Concept of Operations (CONOPS)

- Necessary for correct determination of budgets
- Needs to be designed iteratively with them
 - What orbit?
 - How many and what ground stations?
 - What does the satellite do?
 - Larger project = need for more detail
- More payloads require more operation modes
- More modes require more planning on their interactions
- Usually charging mode, communication mode, payload mode
 - Always also Safe Mode – in case of FDIR event

Constellations Considerations

- Several satellites on similar orbits providing same service
- Primary benefits
 - Throughput
 - Revisit time
 - Redundancy
- Primary downsides
 - Costs
 - CONOPS
 - Complicated interlink
- In many application tradeoff between one large satellite at GEO or constellation at LEO

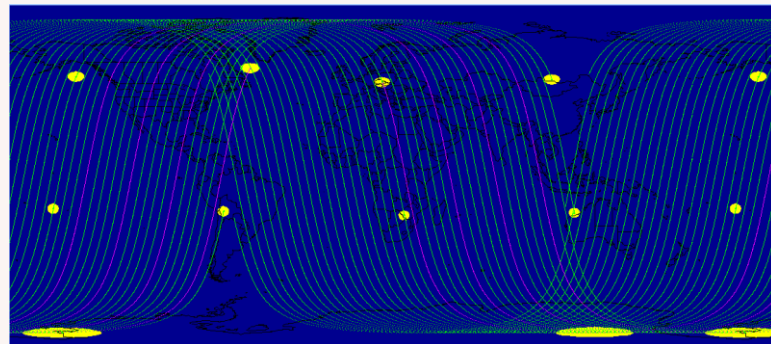
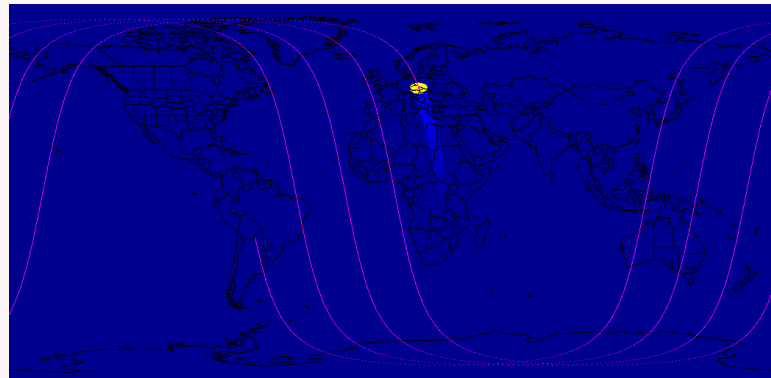

Clean Space Approach

- Simple purpose: “Do not make mess in space”
- Lifetime requirement < 5 years (ESA, New Zealand, later Space Act)
- 4 Major factors when natural decay
 - Mass
 - Size (Drag area against remaining particles)
 - Altitude
 - Solar Activity
- Future considerations: collision avoidance capability, maneuvering, controlled deorbit – as of now, only propulsion makes sense
- Any space debris “catchers” and “removal” devices are non-existent yet

What documents were created?

- Mission Description (objectives, motivation)
- Requirement Specification
- Design Definition [and Justification] (diagrams, budgets, FDIR)
- Verification Plan (test plan, test procedures)
- Interface Control Document (protocols, connectors, commands)
- Operation Plan (Commissioning)
- Space Debris Mitigation Report

- No one is completely following ECSS... consider it but in the end choose what suits you and your team.

Legal Aspects – Object Registration & ITU

- Object registration on national level (ministry) -> UN object registration
- Good source of TLE for US-launched objects: space-track.org
- EU-SST portal – coordination of orbital parameters of European satellites
- EU Space Law est. 2030 – big topic! Major impacts to industry
- National space laws already in effect/development – e.g. Slovakia! Not Czechia yet
- ČTÚ, ITU, IARU: ctu.gov.cz/registrace-druzicove-site
- Radio-amateur x commercial
- Ground station x satellite network



RIDESHARE

Shared costs. Dedicated payload space.
Joint operations included.

- **300 000 € per 1U slot**
- **LAUNCH in 2027 | 2029 | 2031**

OFFER INCLUDES:

- Full Satellite Bus
- Launch & Commissioning
- Operations for 1 year (50 min / day)
- Data Delivery

IOV/IOD, scientific measurements, technology demo, software validation, biological experiments

Visit www.spacemanic.com/rideshare

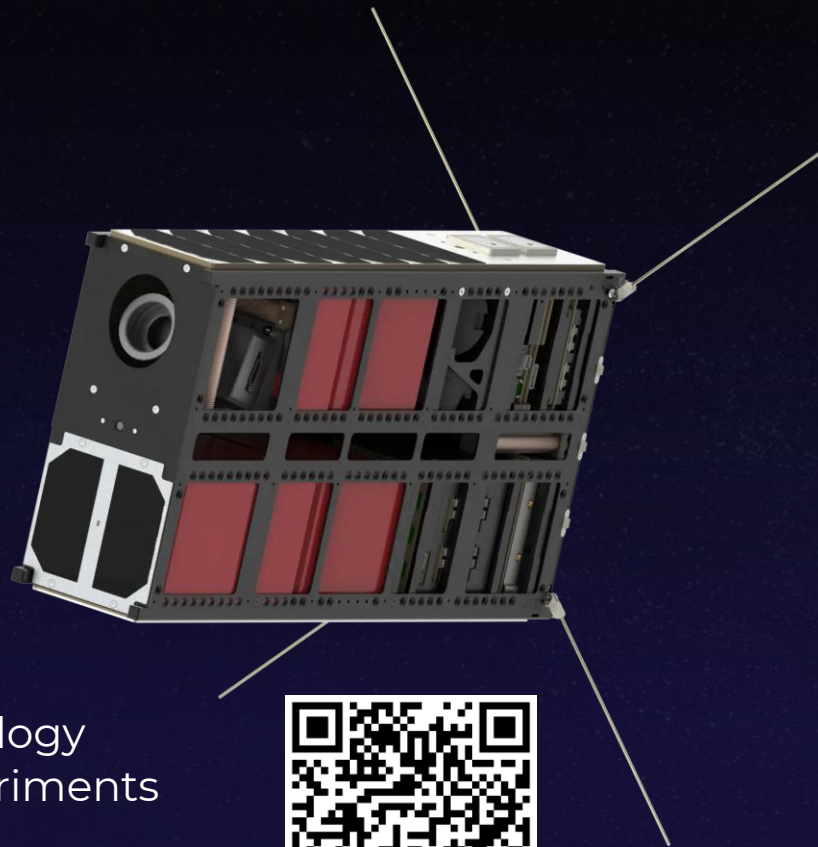

Join us and launch your career! We need brains!



SPACECADET@SPACEMANIC.COM

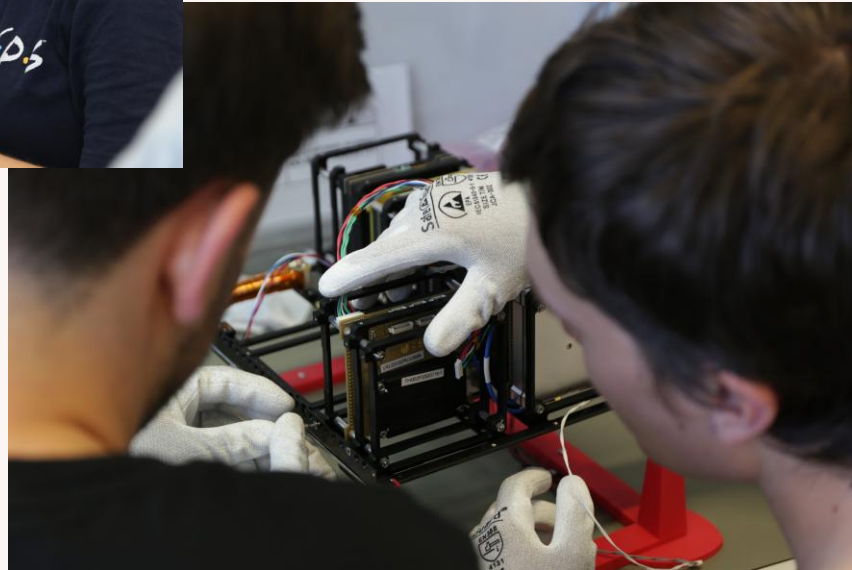

ESERO Česká republika & ESA Academy

www.eserocz.cz



Source: [Kosmonautix](#)

www.esa.int/Education/ESA_Academy



Source: [ESA Website](#)

HEADQUARTERS

Spacemanic CZ s.r.o.
Purkyňova 649/127
612 00 Brno
Czech Republic

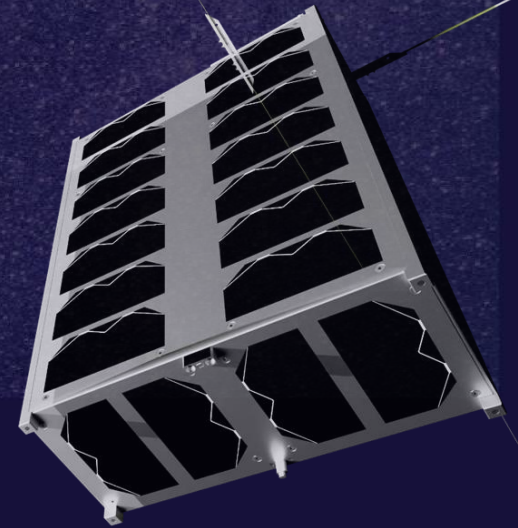

WWW.SPACEMANIC.COM



INFO@SPACEMANIC.COM